



DC Modular highlights

Easy in-system connection access due to top locked covers by convenient thumb screws.

Special fiber reinforced base material offers excellent high temperature properties, good chemical resistance and high strength.

Smart terminal design allows dual mirrored cable lug connections.

Top sides of transparent covers are equipped with recessed locations to properly add custom labels.

Robust transparent covers with breakouts to allow wire access from any direction.

Tin plated high purity copper busses provide maximum conductivity, reducing heat and improving efficiency.

Stainless steel studs, nuts and washers for optimal corrosion resistance.

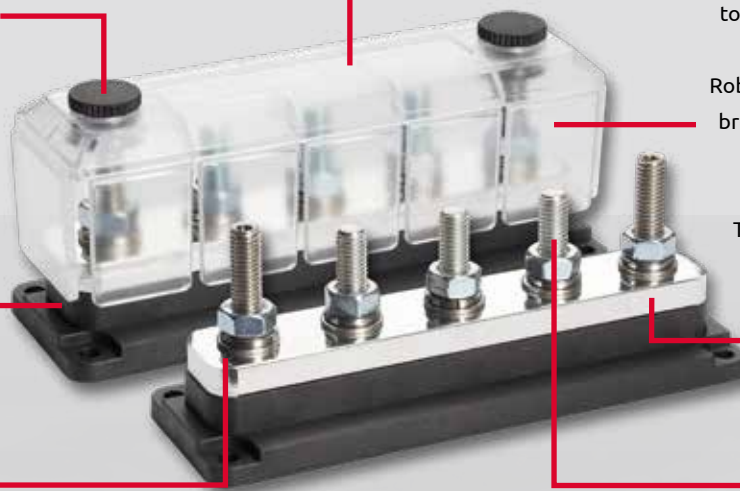

Transparent polycarbonate cover with break-out side skirts at each side, for easy cable entry.



The optional adapter plate allows a mixture of high- and low power cables to be connected to the same stud.



Multiple fuseholders and busbars can be connected to each other with the optional link plates.



Smart terminal design allows dual mirrored cable lug connections.



Application example of a compact DC Modular cluster containing the Expert Modular active shunt, a 3-Stub Busbar and two Fuseholders.

High current Busbars

Description

The DC Modular high current busbars are used to distribute high DC currents to a number of connected cables, or other DC Modular family members.

The solid and compact design, as well as the possibility to link up multiple busbars on a fixed grid, make these products the best choice for all professional DC power systems. The high current busbars are available with M8 or M10 stud sizes.

3 stud Busbar



 **GRID** OPTIMIZED FOOTPRINTS

Model	Art #	Grid size	Max. Current	Max. Voltage ¹⁾	Stud size	Dimensions
DCM 3xM8 Busbar	5073160	1 x 2	600A	60V	M8	100.0 x 50.0 x 64.5 mm
DCM 3xM10 Busbar	5073180	1 x 2	600A	60V	M10	100.0 x 50.0 x 64.5 mm

¹⁾ Higher voltages may require additional safety measures

5 stud Busbar



 **GRID** OPTIMIZED FOOTPRINTS

Model	Art #	Grid size	Max. Current	Max. Voltage ¹⁾	Stud size	Dimensions
DCM 5xM8 Busbar	5075160	1 x 3	600A	60V	M8	150.0 x 50.0 x 64.5 mm
DCM 5xM10 Busbar	5075180	1 x 3	600A	60V	M10	150.0 x 50.0 x 64.5 mm

¹⁾ Higher voltages may require additional safety measures

Insulated Studs

Description

The DC Modular single and dual insulated studs are ideal parts to extend cables, add power taps or form termination end-points.

The solid and compact design, as well as the possibility to link these up with other DC Modular family members, make these products the best choice for all professional DC power systems. The insulated studs are available with M8 or M10 stud sizes.

Single Insulated Stud



Features

- Stainless steel studs, nuts and washers for optimal corrosion resistance
- Special fiber reinforced base material offers excellent high temperature properties, good chemical resistance and high strength
- Unique grid optimized footprints allow space saving arrangements of multiple products
- Common interconnection heights for easy combining of multiple products using link plates
- Robust transparent covers with breakouts to allow wire access from any direction
- Top sides of transparent covers are equipped with recessed locations to properly add custom labels (Dual insulated stud only)
- Smart terminal design allows dual mirrored cable lug connections
- Easy in-system connection access due to top locked covers



Model	Art #	Grid size	Maximum Current	Max. Voltage ¹⁾	Stud size	Dimensions
DCM 1xM8 Single Stud	5071160	1 x 1	N/A	60V	M8	50.0 x 50.0 x 64.5 mm
DCM 1xM10 Single Stud	5071180	1 x 1	N/A	60V	M10	50.0 x 50.0 x 64.5 mm

¹⁾ Higher voltages may require additional safety measures

Dual Insulated Stud



Model	Art #	Grid size	Maximum Current	Max. Voltage ¹⁾	Stud size	Dimensions
DCM 2xM8 Dual Stud	5072160	1 x 1.5	N/A	60V	M8	75.0 x 50.0 x 64.5 mm
DCM 2xM10 Dual Stud	5072180	1 x 1.5	N/A	60V	M10	75.0 x 50.0 x 64.5 mm

¹⁾ Higher voltages may require additional safety measures

Fuseholders

Description

A wide range of fuseholders are available in the DC Modular lineup, covering fuse Amp ratings from 35A up to 600A.

Fuseholders are offered for the Mega®, ANL and Class-T type of fuses, providing solutions for a wide range of applications. The solid and compact design, as well as the possibility to link up multiple fuseholders on a fixed grid, make these products the best choice for all professional DC power systems.

Features

- Stainless steel studs, nuts and washers for optimal corrosion resistance
- Tin plated high purity copper busses provide maximum conductivity, reducing heat and improving efficiency
- Special fiber reinforced base material offers excellent high temperature properties, good chemical resistance and high strength
- Unique grid optimized footprints allow space saving arrangements of multiple products
- Common interconnection heights for easy combining of multiple products using link plates (except Mega and ANL (300A) fuseholders)
- Robust transparent covers with breakouts to allow wire access from any direction
- Smart terminal design allows dual mirrored cable lug connections
- Easy in-system connection access due to top locked covers (except Mega and ANL (300A) fuseholders)

Mega Fuseholder (300A)



Model	Art #	Grid size	Fuse range ¹⁾	Max. Voltage ²⁾	Stud size	Dimensions
DCM Mega Fuseholder	5073300	1 x 1.78 ³⁾	40 .. 300A	60V	M8	89.0 x 50.0 x 53.0 mm

¹⁾ Compatible with Littelfuse® 'Mega' and Cooper Bussmann® 'AMG' fuses

²⁾ Higher voltages may require additional safety measures

³⁾ The Mega fuseholder 300A is optimized for stand-alone use and is not compatible with link- and adapter plates

Mega Fuseholder (500A)



Model	Art #	Grid size	Fuse range ¹⁾	Max. Voltage ²⁾	Stud size	Dimensions
DCM Mega Fuseholder (500A)	5073350	1 x 3	40 .. 500A	60V	M8	150.0 x 50.0 x 64.5 mm

¹⁾ Compatible with Littelfuse® 'Mega' and Cooper Bussmann® 'AMG' fuses

²⁾ Higher voltages may require additional safety measures

ANL Fuseholder (300A)



Model	Art #	Grid size	Fuse range ¹⁾	Max. Voltage ²⁾	Stud size	Dimensions
DCM ANL Fuseholder (300A) M8	5073500	1 x 2 ³⁾	35 .. 300A	60V	M8	100.0 x 50.0 x 53.0 mm
DCM ANL Fuseholder (300A) M10	5073510	1 x 2 ³⁾	35 .. 300A	60V	M10	100.0 x 50.0 x 53.0 mm

¹⁾ M8 version compatible with Littelfuse® 'CNN' and 'CNL' plus Cooper Bussmann® 'ANL' and 'ANN' fuses

M10 version compatible with Littelfuse® '157.57' plus SIBA® '90 058 05' fuses

²⁾ Higher voltages may require additional safety measures

³⁾ The ANL fuseholder has a grid optimized footprint but is not compatible with link- and adapter plates

ANL Fuseholder (600A)



Model	Art #	Grid size	Fuse range ¹⁾	Max. Voltage ²⁾	Stud size	Dimensions
DCM ANL Fuseholder (600A) M8	5073550	1 x 3	35 .. 600A	60V	M8	150.0 x 50.0 x 64.5 mm
DCM ANL Fuseholder (600A) M10	5073560	1 x 3	35 .. 600A	60V	M10	150.0 x 50.0 x 64.5 mm

¹⁾ M8 version compatible with Littelfuse® 'CNN' and 'CNL' plus Cooper Bussmann® 'ANL' and 'ANN' fuses

M10 version compatible with Littelfuse® '157.57' plus SIBA® '90 058 05' fuses

³⁾ Higher voltages may require additional safety measures

Class-T Fuseholder (225-400A)



Model	Art #	Grid size	Fuse range ¹⁾	Max. Voltage ²⁾	Stud size	Dimensions
DCM Class-T Fuseholder (400A)	5073850	1 x 3	225 .. 400A	60V	M10	150.0 x 50.0 x 64.5 mm

¹⁾ Compatible with Littelfuse® 'JLLN', Cooper Bussmann® / Edison® 'JJN' and 'TJN' and Mersen® 'A3T' fuses

²⁾ Higher voltages may require additional safety measures

Class-T Fuseholder (450-600A)



GRID OPTIMIZED FOOTPRINTS



Model	Art #	Grid size	Fuse range ¹⁾	Max. Voltage ²⁾	Stud size	Dimensions
DCM Class-T Fuseholder (600A)	5073880	1 x 3	450 .. 600A	60V	M10	150.0 x 50.0 x 64.5 mm

¹⁾ Compatible with Littelfuse® 'JLLN', Cooper Bussmann® / Edison® 'JJN' and 'TJN' and Mersen® 'A3T' fuses

²⁾ Higher voltages may require additional safety measures

Fuses

Description

In order to complement the high current fuseholders from our DC Modular lineup, we are able to supply the required fuses as well. TBS is a reseller of premium fuse brands Littelfuse and SIBA. For optimal safety, we always advise our customers to use fuses from well known brands. Please contact one of our sales engineers for further advise on which type of fuse to select for your application.

The tables below show the fuse values per type that we keep in stock as standard.



MEGA



ANL



Class-T

Value	Art #
40A / 32Vdc	5097319-2
60A / 32Vdc	5097323-2
80A / 32Vdc	5097327-2
100A / 32Vdc	5097331-2
125A / 32Vdc	5097334-2
150A / 32Vdc	5097337-2
175A / 32Vdc	5097340-2
200A / 32Vdc	5097343-2
250A / 32Vdc	5097349-2
300A / 32Vdc	5097355-2

Value	Art # (M8)	Art # (M10)
50A / 80Vdc	5097521-2	5097621-2
100A / 80Vdc	5097531-2	5097631-2
150A / 80Vdc	5097537-2	5097637-2
200A / 80Vdc	5097543-2	5097643-2
250A / 80Vdc	5097549-2	5097649-2
300A / 80Vdc	5097555-2	5097655-2
350A / 80Vdc	5097557-2	5097657-2
400A / 80Vdc	5097559-2	5097659-2
500A / 80Vdc	5097563-2	5097663-2
600A / 80Vdc	5097565-2	-

Value	Art #
225A / 125Vdc	5097846-1
300A / 125Vdc	5097855-1
400A / 125Vdc	5097859-1
450A / 125Vdc	5097861-1
600A / 125Vdc	5097865-1

Other fuse values on request

DC Modular

Remote Battery Switch / Battery Protect Relay



Description

The DC Modular Remote Battery Switch (RBS) and Battery Protect Relay (TBP) are smart high current magnetic latching contactors, that can handle continuous DC currents of up to 500Amps. The contactors can easily be installed in an engine room or battery compartment, while being controlled from a more convenient location by a small panel mounted switch. The RBS / TBP can however also be controlled by a battery monitor or managed lithium battery.

Besides controlling the contactors remotely, buttons positioned at the top also provide a way to open or close the main contact locally, as required by Marine Standards. A 5 wire interface cable is used to control the contactors externally. For optimal flexibility, these can be configured to accept two wire or single wire open and close commands. A wire for providing a contact status feedback signal is also available.

Status LEDs on top clearly indicate whether the main contact is opened or closed. These indicators also provide additional visual feedback like operating- and error modes.

A specially developed internal solenoid guarantees a powerful contact drive, even when supplied by deeply discharged batteries.

Both the RBS and the TBP can be used to switch battery loads, through local and/or external control. The TBP however, has a number of additional features. The most important one being built-in battery protection.

The TBP will automatically open the main contact once the battery voltage has dropped below a programmable low voltage level. When subsequently the battery voltage has risen above the programmable reconnect voltage, the main contact is closed again.

Another handy TBP feature is the Override mode. In situations where the TBP has opened the main contact due to a battery undervoltage, long-pressing the close button (local or external) will close the main contact for 1 minute. This allows the user to jumpstart a low battery system. When after this minute the battery voltage remains too low, the contact will open up again. But it remains closed when during the override time, a charger has been connected causing the battery voltage to recover.

Being a member of the DC Modular product line up, the RBS and TBP can be perfectly integrated into very compact DC distribution systems.

Features

- Electronically controlled magnetic latching contactor
- Extremely low power consumption (< 100µA)
- Up to 500Amp nominal current
- 60Vdc contact rating
- Local and external open / close control
- Visual status indicators

- Small footprint
- DC Modular grid compatible for compact and easy arrangements of multiple devices
- Selectable control modes
- Battery protection (TBP only)
- Override mode (TBP only)

Applications

- Battery management systems
- Marine applications
- Off grid solar power systems
- Battery load shedding applications
- Service vehicles
- Recreational vehicles
- Industrial systems

Technical specifications

Parameter	DCM-RBS-12-500 (art # 5074510)	DCM-RBS-24-500 (art # 5074520)	DCM-RBS-48-350 (art # 5074540)	DCM-TBP-12-500 (art # 5074410)	DCM-TBP-24-500 (art # 5074420)	DCM-TBP-48-350 (art # 5074440)
Main contact circuit (electrical)						
Rated voltage	60Vdc					
Nominal current	500A					
Cranking current (1min.)	1000A					
Nominal make / break current	500A (0 - 34Vdc)		350A (35 - 60Vdc)			
Peak make / break current	1600A (0 - 34Vdc)		1200A (35 - 60Vdc)			
Control circuit (electrical)						
Coil / supply voltage (+Vdc)	7.5 - 17Vdc	15 - 34Vdc	34 - 68Vdc	7.5 - 17Vdc	15 - 34Vdc	34 - 68Vdc
Coil / supply current (idle state) ¹⁾	< 100uA					
Coil / supply current (state change) ¹⁾	< 6A	< 3A	< 1.5A	< 6A	< 3A	< 1.5A
Features						
Remote battery switch function	•	•	•	•	•	•
Battery protect function	x	x	x	•	•	•
Local open / close controls	•	•	•	•	•	•
External open / close control wires	•	•	•	•	•	•
Contact status indicators	•	•	•	•	•	•
Contact status feedback wire	•	•	•	•	•	•
Override mode ²⁾	x	x	x	•	•	•
Number of control modes	5	5	5	7	7	7
Programmable disconnect voltages	x	x	x	9.0 - 12.2Vdc	18.0 - 24.5Vdc	36.0 - 49.0Vdc
Programmable reconnect voltages	x	x	x	10.5 - 13.8Vdc	21.0 - 27.5Vdc	42.0 - 55.0Vdc
General						
Remote control	By control wires					
Local control ³⁾	Top side buttons (On/Standby, Close contact, Open contact)			Top side buttons (On/Standby, Close contact, Open contact, Override mode)		
Indicators	Top side LEDs for Contact open, Contact closed, Error and Setup					
Mechanical / Electrical life	100000 cycles / 10000 cycles					
Operating temperature range	-20..+60°C					
Connection stud size	M10					
DC Modular grid size	1 x 3					
Protection class	IP65					
Dimensions	150.0 x 50.0 x 94.0 mm					
Weight	800gr					
Standards	CE certified (EMC Directives UNECE Regulation 10 (only 12V and 24V models) and 2014/30/EU, Low voltage Directive 2014/35/EU, RoHS Directive 2011/65/EU and Ignition protection standard ISO 8846)					

Note: the given specifications are subject to change without notice.

¹⁾ Due to the magnetic latch construction, the DCM RBS and TBP draw virtually no current in the ON or OFF state. A current draw only exists shortly (500ms max) when changing the state of the contact.

²⁾ Override mode allows the contact to be temporarily closed, despite being automatically opened earlier due to a battery under voltage. This is intended for jumpstarting a low battery system.

³⁾ Using the top side buttons, one can manually override the switch state as commanded through the control wires. A dedicated 'On/Standby' button also allows the user to put the DCM RBS or TBP in a standby mode with open contact. In this mode any commands from the control wires and/or manual override buttons are ignored.



Accessories

Panel Switch Momentary SPDT + LED art# 5095000-1

With this optional panel switch you can send open and close commands to the RBS and TBP contactors from a convenient location. The integrated LED indicates when the contact is closed or when the contactor is running in a certain mode.

Accessories

Description

Due to the common interconnection heights, smart space saving arrangements of multiple DC Modular products can be made by linking these together using the optional Link Plates.

We have managed to offer only three Link Plate sizes to create all possible combinations. All Link Plates are compatible with M8 and M10 studs. Additionally, we have equipped some Link Plates with two M4 screws to provide convenient connection points for smaller cables.

For this purpose only, we are also offering an Adapter Plate which allows a mixture of high and low power cables to be connected to the same stud. The Adapter Plate can be used on M8 and M10 studs and offers four connection points for smaller cables.

Features

- Tin plated high purity copper busses provide maximum conductivity, reducing heat and improving efficiency
- Stainless steel M4 screws and washers provide convenient connection points for smaller cables
- Compatible with M8 and M10 studs

Link Plate 41 mm



Model ¹⁾	Art #	Max. Current ²⁾	Dimensions (L x W)	Accepts stud size
DCM Link Plate 41 mm	5079062	600A	63.0 x 25.0 mm	M8 + M10

¹⁾ Not compatible with "Mega (300A)" and "ANL (300A)" fuseholders

²⁾ Current capacity can be doubled by stacking two Link Plates (after removal of M4 screws)

End to end linking

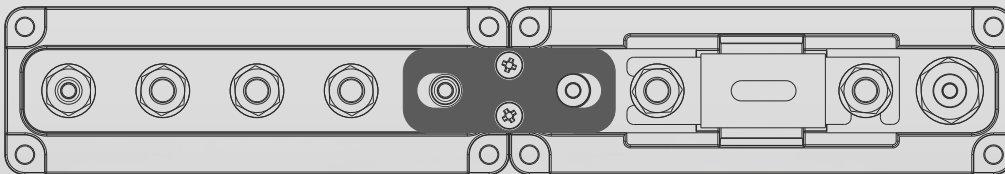

For linking to and from:

- DCM 2xM8/M10 Dual Stud
- DCM 3xM8/M10 Busbar
- DCM 5xM8/M10 Busbar
- DCM Mega Fuseholder (60V/500A)
- DCM ANL Fuseholder (60V/600A)
- DCM Class-T Fuseholder (60V/225-400A)
- DCM Class-T Fuseholder (60V/450-600A)
- DCM RBS / TBP

End to side linking

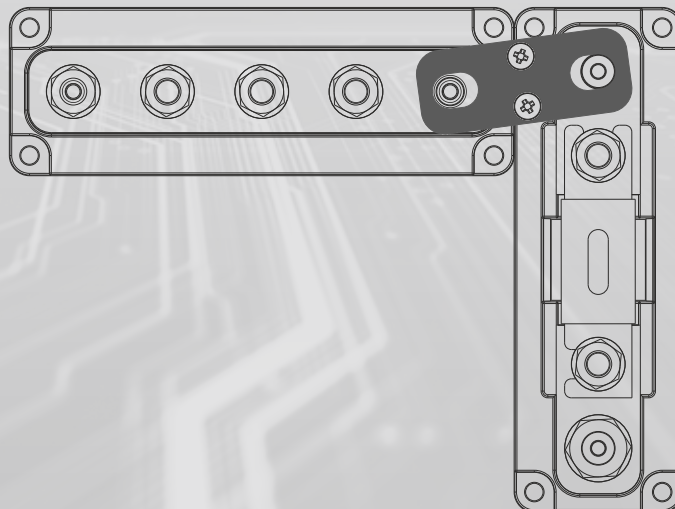

For linking to and from:

- DCM 2xM8/M10 Dual Stud
- DCM 3xM8/M10 Busbar
- DCM 5xM8/M10 Busbar
- DCM Mega Fuseholder (60V/500A)
- DCM ANL Fuseholder (60V/600A)
- DCM Class-T Fuseholder (60V/225-400A)
- DCM Class-T Fuseholder (60V/450-600A)
- DCM RBS / TBP

Link Plate 50 mm

Link Plate 3 Way 50 mm



Model ¹⁾	Art #	Max. Current ²⁾	Dimensions (L x W)	Accepts stud size
DCM Link Plate 50 mm	5079072	600A	75.0 x 25.0 mm	M8 + M10
DCM Link Plate 3 Way 50 mm	5079073	600A	125.0 x 25.0 mm	M8 + M10

¹⁾ Not compatible with "Mega (300A)" and "ANL (300A)" fuseholders
²⁾ Current capacity can be doubled by stacking two Link Plates

Side to side linking (two positions)

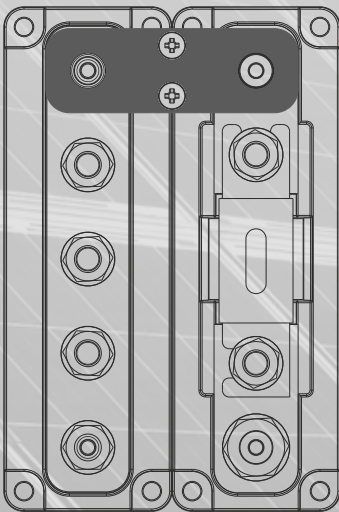

For linking to and from:

- DCM 1xM8/M10 Single Stud
- DCM 2xM8/M10 Dual Stud
- DCM 3xM8/M10 Busbar
- DCM 5xM8/M10 Busbar
- DCM Mega Fuseholder (60V/500A)
- DCM ANL Fuseholder (60V/600A)
- DCM Class-T Fuseholder (60V/225-400A)
- DCM Class-T Fuseholder (60V/450-600A)
- DCM RBS / TBP

Side to side linking (three positions)

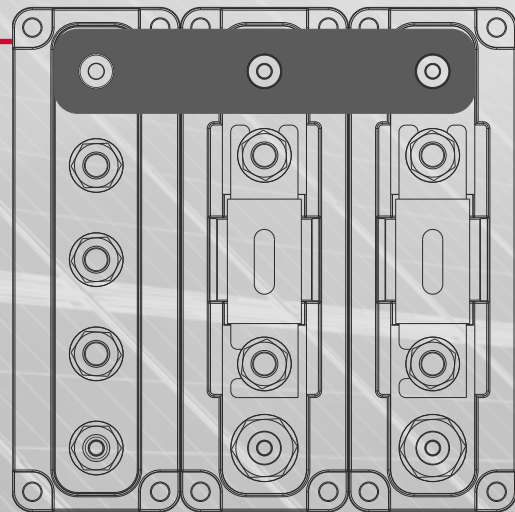

Adapter Plate



Model ¹⁾	Art #	Max. Current	Dimensions (L x W)	Accepts stud size
Adapter Plate (1xM8/M10 to 4xM4)	5079020	600A	46.0 x 25.0 mm	M8 + M10

¹⁾ Not compatible with "Mega (300A)" and "ANL (300A)" fuseholders

For converting an M8 or M10 stud to 4xM4 fork/ring terminals

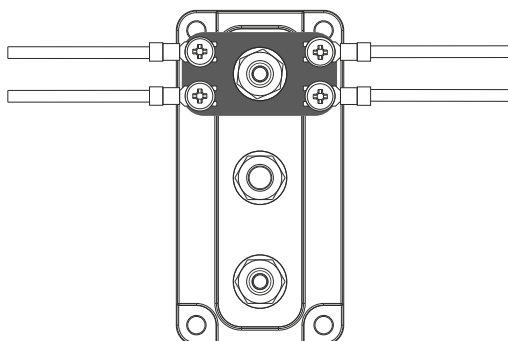

Dimensions (3 Stud Busbar)

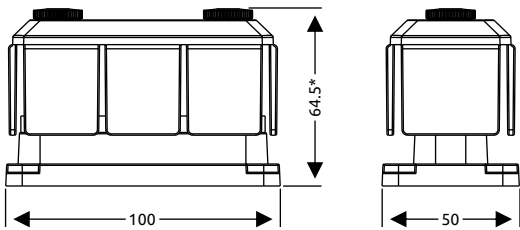

* Total height without cover is 56.3 mm

Dimensions (5 Stud Busbar, Mega Fuseholder 500A, ANL Fuseholder 600A, Class-T Fuseholder 225-400A, Class-T Fuseholder 450-600A)

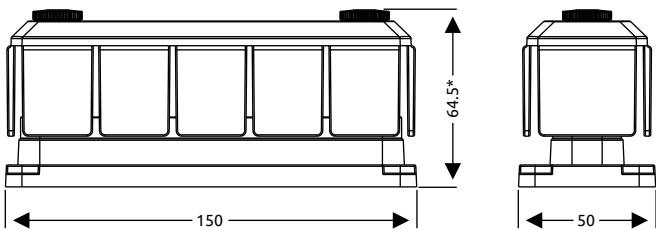

* Total height without cover is 56.3 mm

Dimensions (Single Insulated Stud)

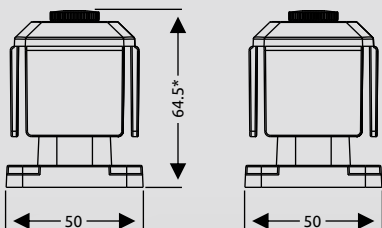

* Total height without cover is 56.3 mm

Dimensions (Dual Insulated Stud)

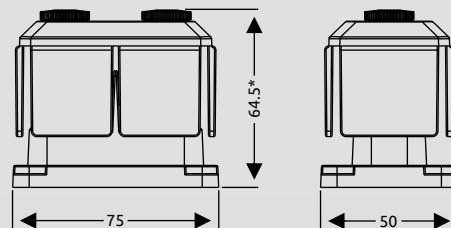

* Total height without cover is 56.3 mm

Dimensions (Mega Fuseholder 300A)

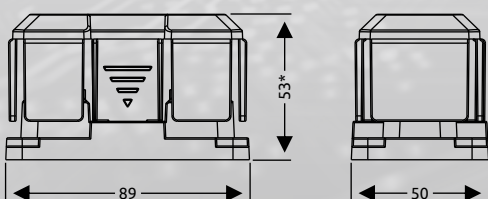

* Total height without cover is 43.5 mm

Dimensions (ANL Fuseholder 300A)

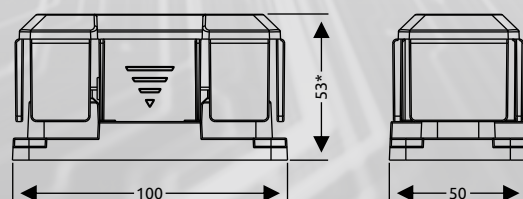

* Total height without cover is 43.5 mm

Dimensions (Contactors)

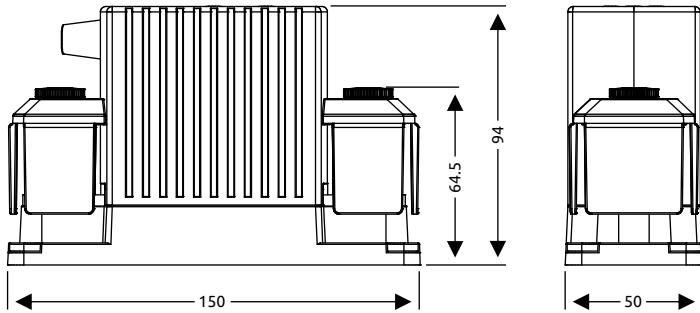

Dimensions (Link Plate 41 mm)

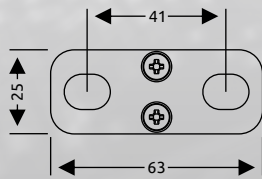

Dimensions (Link Plate 50 mm)

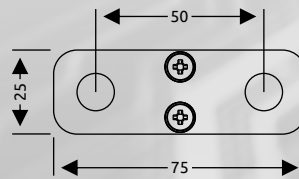

Dimensions (Link Plate 3 Way 50 mm)

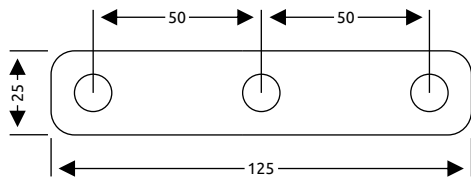

Dimensions (Adapter Plate)

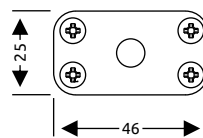

Measurement units: millimeters