

# 4500

## Controllable pitch propeller

▼ This system permits to control the engine speed (rpm) and tune the propeller pitch



The command station is a «dual lever control»: one lever (red) controls the engine speed and the second lever (black) controls the propeller pitch. This allows an accurate and precise fine tuning of the boat speed.



## SYSTEM CONFIGURATION

This system is composed by:

- one Actuator Box to control (through two mechanical push pull cables) the engine throttle and the propeller pitch control;
- one Command Station with two levers, one for the throttle control (red color) and the other for the propeller pitch control (black color)
- a CANBus cable to connect the Actuator Box to the Command Station, whose length is in the range 3m 200m.

The system, once enabled, permits to "drive by wire" both the speed and the propeller pitch.

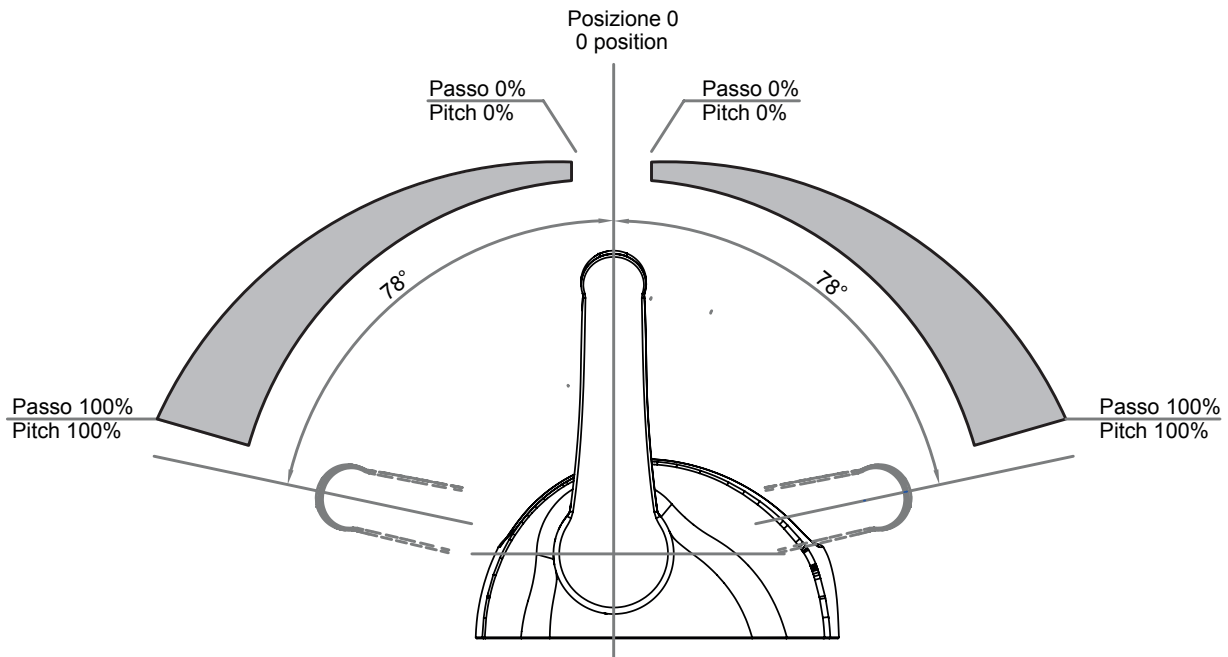

Funzionamento leva di comando del passo dell'elica (colore nero)  
Functioning of the pitch propeller command lever (black)

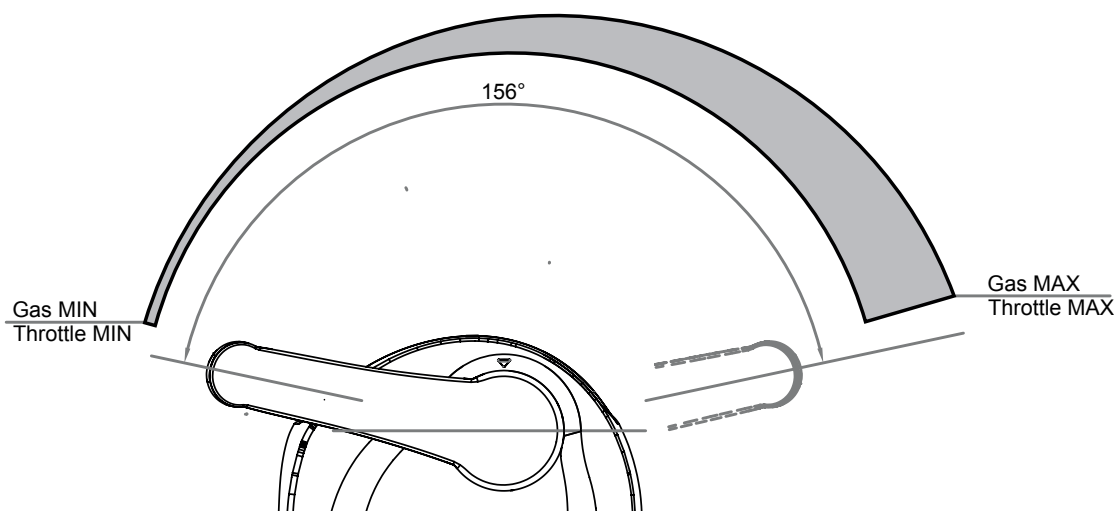

Funzionamento leva di comando del motore (colore rosso)  
Functioning of the engine throttle command lever (red)

**Flexball Italiana S.r.l.**

Via San Luigi 13/A - 10043 Orbassano (To) - Italy

Tel 0039.011 90.38.900 - Fax 0039.011 90.38.747

info@flexballitaliana.com

[www.flexballitaliana.com](http://www.flexballitaliana.com)

**FLEXBALL**  
ITALIANA  
WR CONTROLS GROUP

